



# *Illustrated Parts List*

## *Pressure Washer / Lavadora de Presión*



This pressure washer is rated in accordance to the Pressure Washer Manufacture Association (PWMA) Standard PW101 (Testing and Rating Performance of Pressure Washers).

Questions? Help is just a moment away!  
Preguntas? La ayuda es justa un momento lejos!  
Call: Pressure Washer Helpline

Llame: Línea Directa del Lavadora a Presión - 1-800-743-4115 M-F 8-5 CT

### **Model / Modelo**

<b>Mfg. No.</b>	<b>Description / Descripción</b>
020542-00	3,300 PSI Briggs & Stratton

**Manual Part No.** 319062

Revision C

Rev. Date: 6/16/2015

Not for  
Reproduction

<b>PRODUCT COMPONENTS</b>	<b>PAGES</b>
Main Unit .....	4
Pump .....	7
<b>Torque Specification Chart .....</b>	<b>Inside Back Cover</b>

Not for  
Reproduction

# Main Unit

318557

**NOTE:** Unless noted otherwise, use the standard hardware torque specification chart.

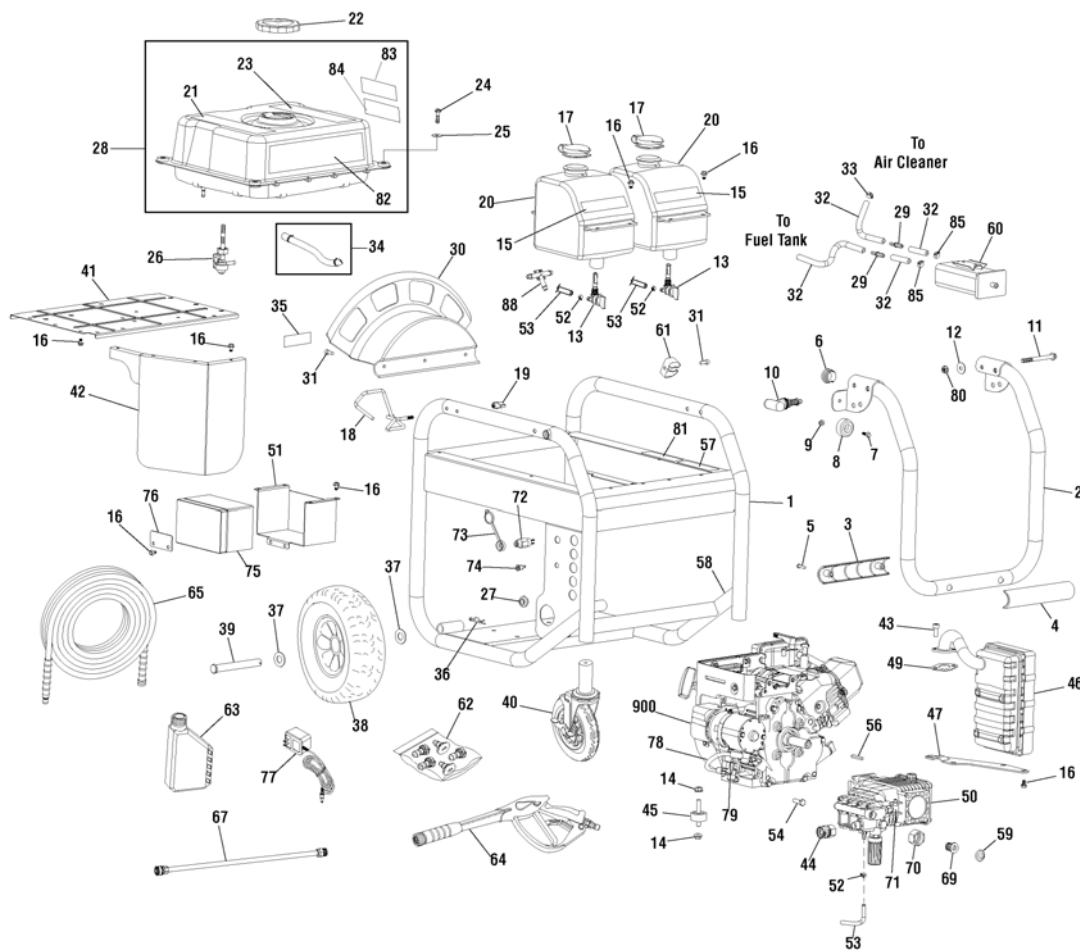

REF.	PART NO.	DESCRIPTION	REF.	PART NO.	DESCRIPTION
1	318445GS	BASE	18	318468GS	WIREFORM
2	318454GS	HANDLE	19	194289GS	KNOB
3	316502GS	GRIP, Handle	20	315530GS	TANK, Chemical
4	316501GS	GRIP, Handle	21	318603GS	DECAL
5	-----	* SCREW, M5-0.8 x 20	22	316670GS	CAP, Fuel
6	316712GS	CAP, Plug	23	316778GS	DECAL
7	706865	SCREW	24	706866	SCREW
8	316713GS	MOUNT, Vibration	25	312005GS	WASHER
9	-----	* NUT, M6 1.0	26	209417GS	VALVE, Fuel
10	316732GS	T-KNOB	27	706895	GROMMET
11	316508GS	SCREW	28	319061GS	TANK, Fuel
12	706926	WASHER	29	317025GS	BARB, Hose
13	317106GS	VALVE, Chemical Tank	30	316374GS	WRAP, Hose
14	-----	* NUT, Flange, M8	31	318992GS	SCREW
15	318482GS	DECAL	32	315017GS	HOSE, Vapor (Cut to Fit)
16	706152	SCREW	33	48031JGS	CLAMP
17	316764GS	CAP, Chemical Tank			

### Footnotes

Note:\* Items without part numbers are common fasteners and are available at your local hardware store.

The above parts group applies to the following Mfg. Nos.:

020542-00 - 3,300 PSI Briggs & Stratton

# Main Unit

318557

**NOTE:** Unless noted otherwise, use the standard hardware torque specification chart.

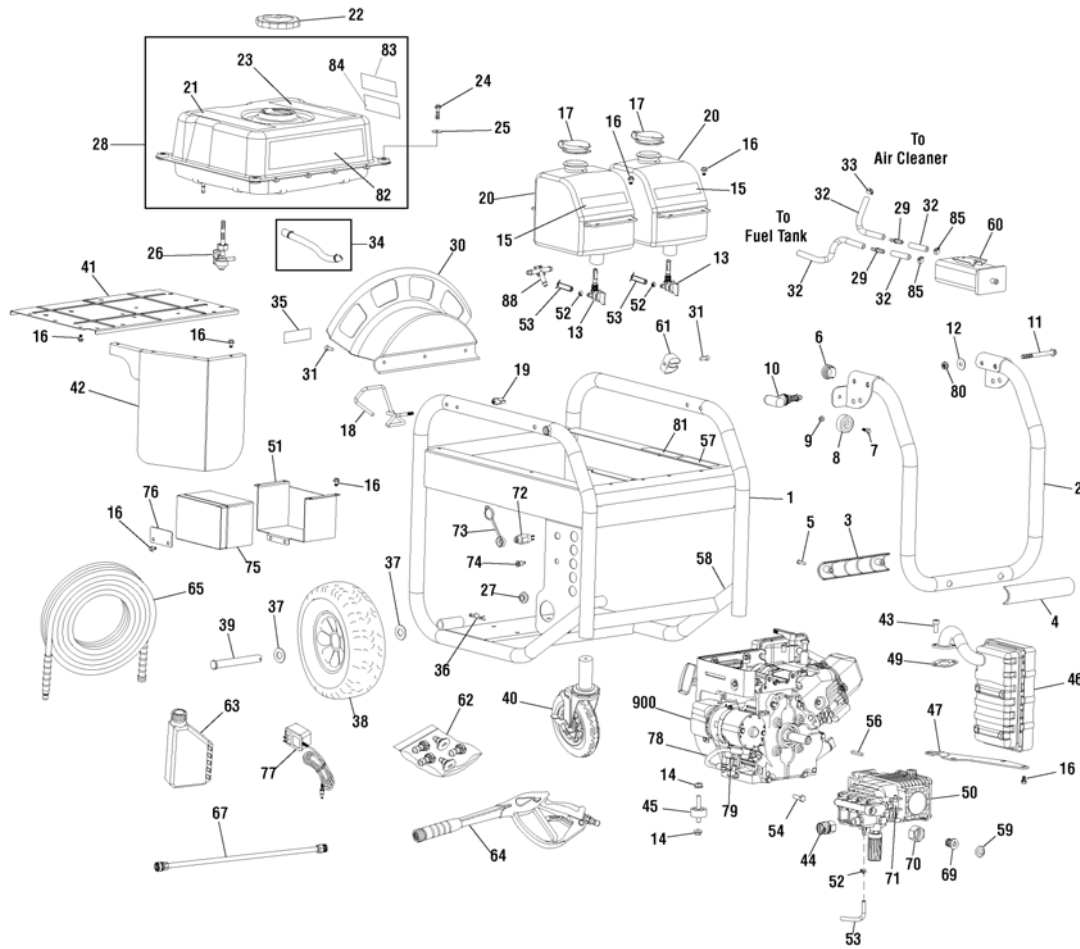

REF. PART NO.	DESCRIPTION	REF. PART NO.	DESCRIPTION
34	791745 KIT, Fuel Hose (Cut to Fit)	52	48031GGS CLAMP
35	318608GS DECAL	53	A1040DGS HOSE, Chemical
36	5025210YP PIN, Hair	54	----- * SCREW, 5/16-24 x 1
37	----- * WASHER, Flat, 5/8"	56	23139DGS KEY
38	316406GS WHEEL	57	318602GS DECAL
39	317577GS AXLE	58	200310GS DECAL
40	316405GS WHEEL, Caster	59	B2384GS FILTER, Garden Hose
41	316504GS HEATSHIELD	60	316783GS CARBON CANISTER
42	316505GS HEATSHIELD	61	316503GS CLIP
43	706921 SCREW	62	208324GS KIT, Nozzle
44	703824 FITTING	--	198841GS NOZZLE, QC Black
45	21217GS MOUNT, Vibration	--	195983NGS NOZZLE, QC Red
46	188301GS MUFFLER	--	195983QGS NOZZLE, QC Green
47	191785GS BRACKET, Muffler	--	195983PGS NOZZLE, QC Yellow
49	697815 GASKET	--	195983RGS NOZZLE, QC White
50	317944GS PUMP	63	316768GS OIL BOTTLE
51	316511GS TRAY, Battery	64	318451GS GUN

**Footnotes**

Note:\* Items without part numbers are common fasteners and are available at your local hardware store.

The above parts group applies to the following Mfg. Nos.:

**020542-00 - 3,300 PSI Briggs & Stratton**

# Main Unit

318557

**NOTE:** Unless noted otherwise, use the standard hardware torque specification chart.

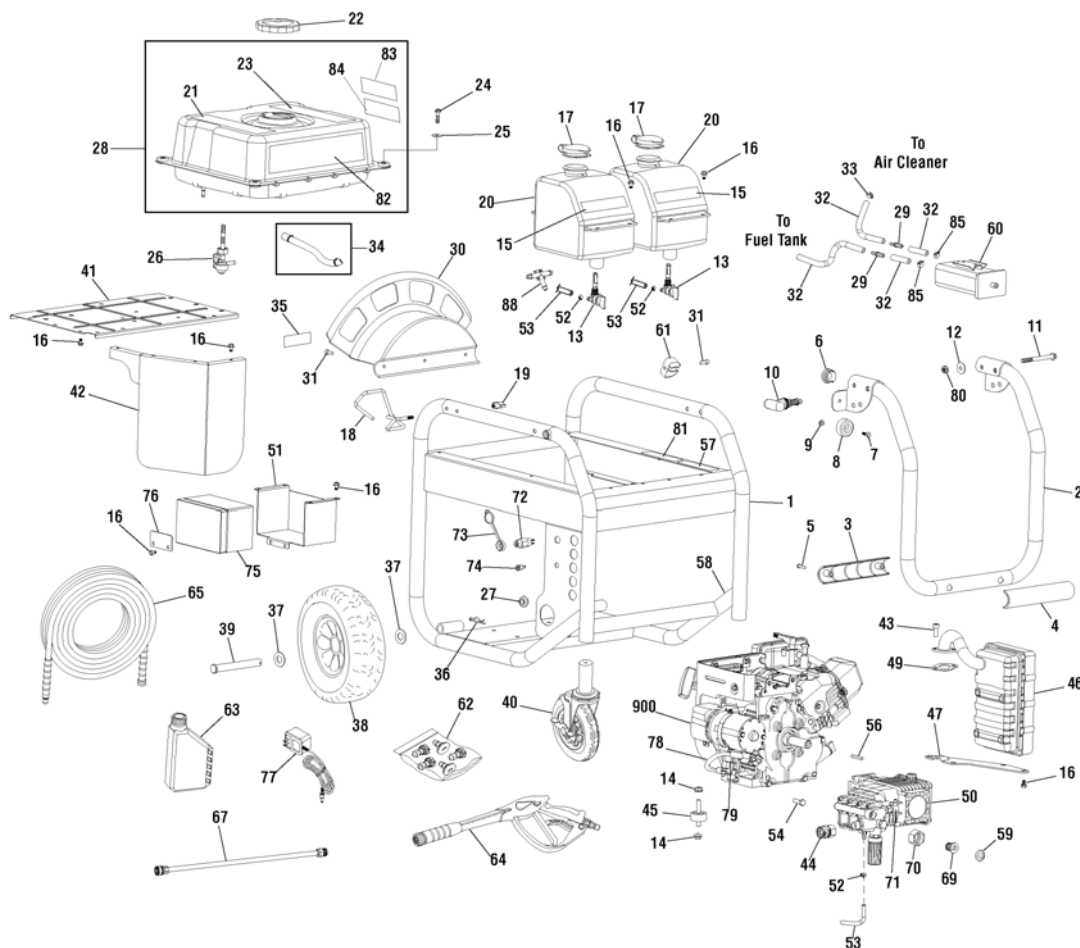

REF. PART NO.	DESCRIPTION	REF. PART NO.	DESCRIPTION		
65	318452GS	HOSE	84	200672GS	DECAL
67	207785GS	EXTENSION	85	204024GS	CLAMP
69	195894GS	FITTING	88	192635GS	BARB-HOSE
70	195893GS	CONNECTOR	900	----	** ENGINE
71	208673GS	VALVE, Thermal Relief	--	316782GS	WRENCH, Allen (Not Illustrated)
72	692318	SWITCH	--	317365GS	OIL FUNNEL (Not Illustrated)
73	312687GS	BOOT, Rubber	--	317898GS	CABLE, Battery, Red (Not Illustrated)
74	186168GS	JACK, Coaxial	--	317943GS	CABLE, Battery, Black (Not Illustrated)
75	316543GS	BATTERY	--	691959	KEY (Not Illustrated)
76	316729GS	COVER, Battery	--	6039	PUMP SAVER (Optional Accessory - Not Included)
77	B4177GS	CHARGER, Battery	--	705001	KIT-O RINGS (Optional Accessory - Not Included)
78	690795	CABLE ASSEMBLY			
79	557067	BRACKET SOLENOID ASSY			
80	316509GS	NUT			
81	200538GS	DECAL			
82	318610GS	DECAL			
83	319020GS	DECAL			

## Footnotes

Note:\* Items without part numbers are common fasteners and are available at your local hardware store.

The above parts group applies to the following Mfg. Nos.:

020542-00 - 3,300 PSI Briggs & Stratton

# Pump

316158

**NOTE:** Unless noted otherwise,  
use the standard hardware torque  
specification chart.

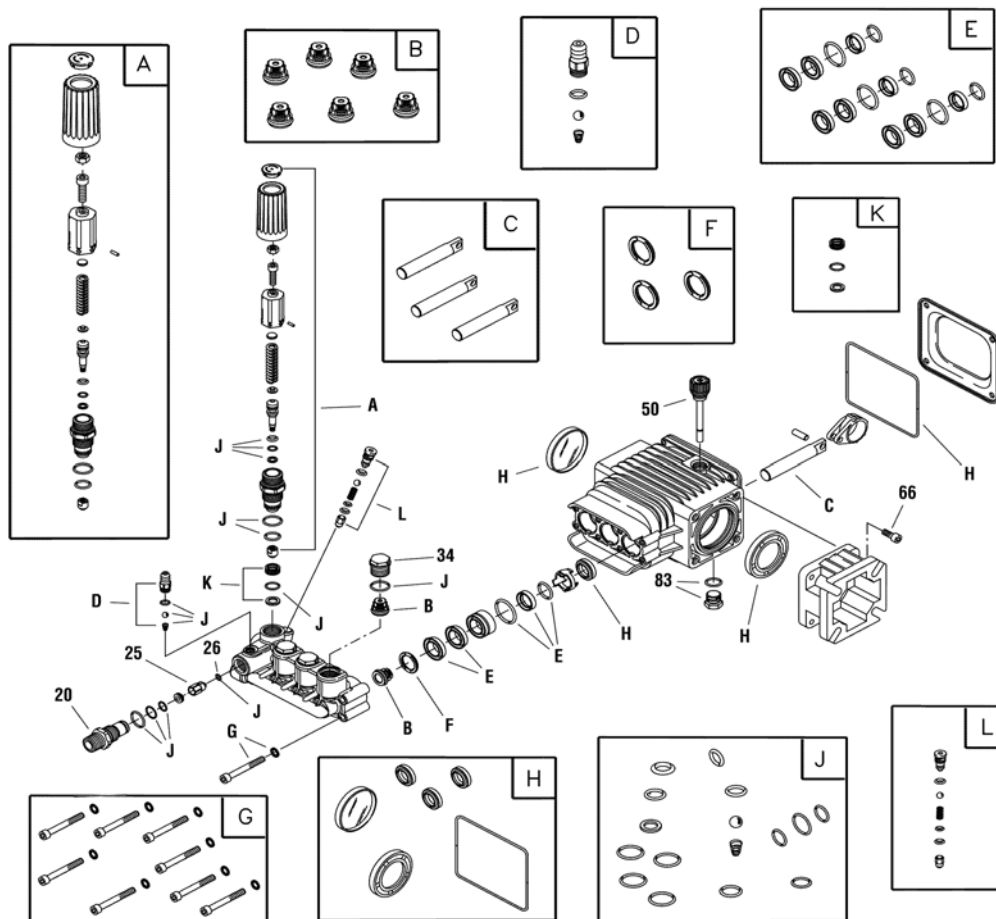

REF.	PART NO.	DESCRIPTION	REF.	PART NO.	DESCRIPTION
20	198851GS	INJECTOR, Detergent	L	202800GS	KIT, Unloader
25	204860GS	JET	--	B2384GS	FILTER, Garden Hose (Not Illustrated)
26	204859GS	O-RING	--	6039	PUMP SAVER (Optional Accessory)
34	198850GS	CAP, Check Valve			
50	198849GS	DIPSTICK			
66	198297GS	SCREW			
83	203034GS	PLUG, Drain			
A	198736GS	KIT, Unloader			
B	198843GS	KIT, Check Valve			
C	198844GS	KIT, Piston			
D	192914GS	KIT, Chemical Injector			
E	198845GS	KIT, Water Seal			
F	198848GS	KIT, Support Ring			
G	198852GS	KIT, Hardware			
H	198846GS	KIT, Oil Seals			
J	198847GS	KIT, O- Ring			
K	202902GS	KIT, Unloader Seat			

## Footnotes

The above parts group applies to the following Mfg. Nos.:

020542-00 - 3,300 PSI Briggs & Stratton

Not for  
Reproduction



Not for  
Reproduction

Not for  
Reproduction

# Hardware Identification & Torque Specifications

Torque Specification Chart								
FOR STANDARD METRIC MACHINE HARDWARE (Tolerance ± 20%)								
Property Class	5.6		8.8		10.9		12.9	
	Class 5.6		Class 8.8		Class 10.9		Class 12.9	
Size Of Hardware	in/lbs		in/lbs		in/lbs		in/lbs	
	ft/lbs	Nm.	ft/lbs	Nm.	ft/lbs	Nm.	ft/lbs	Nm.
M3	5.88	.56	13.44	1.28	19.2	1.80	22.92	2.15
M4	13.44	1.28	30.72	2.90	43.44	4.10	52.56	4.95
M5	26.4	2.50	60.96	5.75	5.97	8.10	7.15	9.7
M6	44.64	4.3	7.3	9.9	10.3	14	12.1	16.5
M7	5.2	7.1	12.1	16.5	16.9	23	19.9	27
M8	7.7	10.5	17.7	24	25	34	29	40
M10	15	21	35	48	50	67	59	81
M12	26	36	61	83	86.2	117	103	140
M14	42	58	101	132	136	185	162	220
M16	64	88	147	200	210	285	250	340
M18	89	121	202	275	287	390	346	470
M20	126	171	290	390	405	550	486	660
M22	169	230	390	530	559	745	656	890
M24	217	295	497	375	708	960	840	1140
M27	320	435	733	995	1032	1400	1239	1680
M30	435	590	995	1350	1401	1900	1681	2280
M33	590	800	1349	1830	1902	2580	2278	3090
M36	759	1030	1740	2360	2441	3310	2935	3980
M39	988	1340	2249	3050	3163	4290	3798	5150

The guides and ruler furnished below are designed to help you select the appropriate hardware.



Nut, M8

Thread Diameter (mm)  
Inside Diameter (in)  
Threads per inch

Nut, 1/2-16

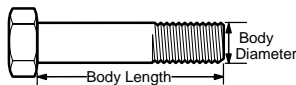

Screw, M8- 1.25 x 25

Thread Diameter (mm)  
Body Diameter  
Distance between threads (mm)  
Threads per inch  
Body Length (mm)  
Body Length (in)

Screw, 1/2- 16 x 2

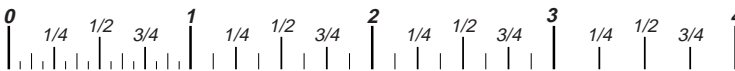

## Standard Hardware Sizing

When a washer or nut is identified as 1/2" (M8), this is the *Nominal size*, meaning the *inside diameter* is 1/2 inch (8mm metric thread diameter); if a second number is present it represents the *threads per inch* (distance between threads).

When bolt or capscrew is identified as 1/2 - 16 x 2" (M8 - 1.25 x 50), this means the *Nominal size*, or body diameter is 1/2 inch (8mm metric thread diameter), the second number, 16, represents the *threads per inch*, (1.25 thread diameter). The final number is the body length of the bolt or screw, 2 inches (50mm).

Torque Specification Chart						
FOR STANDARD MACHINE HARDWARE (Tolerance ± 20%)						
Hardware Grade	No Marks		SAE Grade 5		SAE Grade 8	
	SAE Grade 2		SAE Grade 5		SAE Grade 8	
Size Of Hardware	in/lbs		in/lbs		in/lbs	
	ft/lbs	Nm.	ft/lbs	Nm.	ft/lbs	Nm.
8-32	19	2.1	30	3.4	41	4.6
8-36	20	2.3	31	3.5	43	4.9
10-24	27	3.1	43	4.9	60	6.8
10-32	31	3.5	49	5.5	68	7.7
1/4-20	66	7.6	8	10.9	12	16.3
1/4-28	76	8.6	10	13.6	14	19.0
5/16-18	11	15.0	17	23.1	25	34.0
5/16-24	12	16.3	19	25.8	29	34.0
3/8-16	20	27.2	30	40.8	45	61.2
3/8-24	23	31.3	35	47.6	50	68.0
7/16-14	30	40.8	50	68.0	70	95.2
7/16-20	35	47.6	55	74.8	80	108.8
1/2-13	50	68.0	75	102.0	110	149.6
1/2-20	55	74.8	90	122.4	120	163.2
9/16-12	65	88.4	110	149.6	150	204.0
9/16-18	75	102.0	120	163.2	170	231.2
5/8-11	90	122.4	150	204.0	220	299.2
5/8-18	100	136	180	244.8	240	326.4
3/4-10	160	217.6	260	353.6	386	525.0
3/4-16	180	244.8	300	408.0	420	571.2
7/8-9	140	190.4	400	544.0	600	816.0
7/8-14	155	210.8	440	598.4	660	897.6
1-8	220	299.2	580	788.8	900	1,244.0
1-12	240	326.4	640	870.4	1,000	1,360.0

## NOTES

- These torque values are to be used for all hardware excluding: locknuts, self-tapping screws, thread forming screws, sheet metal screws and socket head setscrews.
- Recommended seating torque values for locknuts:
  - for prevailing torque locknuts - use 65% of grade 5 torques.
  - for flange whizlock nuts and screws - use 135% of grade 5 torques.
- Unless otherwise noted on assembly drawings, all torque values must meet this specification.

## Common Hardware Types

Hex Head Capscrew



Washer



Lockwasher

Carriage Bolt



Hex Nut

## Wrench & Fastener Size Guide

1/4" Bolt or Nut Wrench—7/16"	5/16" Bolt or Nut Wrench—1/2"	3/8" Bolt or Nut Wrench—9/16"	7/16" Bolt or Nut Wrench (Bolt)—5/8" Wrench (Nut)—11/16"	1/2" Bolt or Nut Wrench—3/4"
M6 Bolt or Nut Wrench—10mm	M8 Bolt or Nut Wrench—13mm	M10 Bolt or Nut Wrench—17mm	M12 Bolt or Nut Wrench—19mm	M14 Bolt or Nut Wrench—22mm



Not for  
Reproduction

**Briggs & Stratton Power Products Group, LLC**

Copyright© 2015 Briggs & Stratton Power Products Group, LLC. All rights reserved. No part of this page can be reproduced or transmitted in any form by any means without the express written permission of Briggs & Stratton Power Products Group, LLC.